

# SL20C plissé

## SL22C plissé

PLEATED BLIND

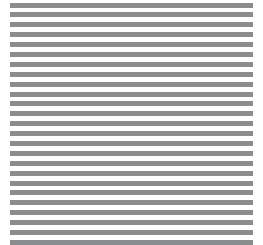
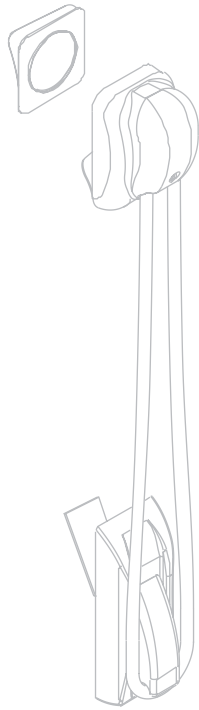

ScreenLine®

ScreenLine

# SL20C plissé

## SL22C plissé

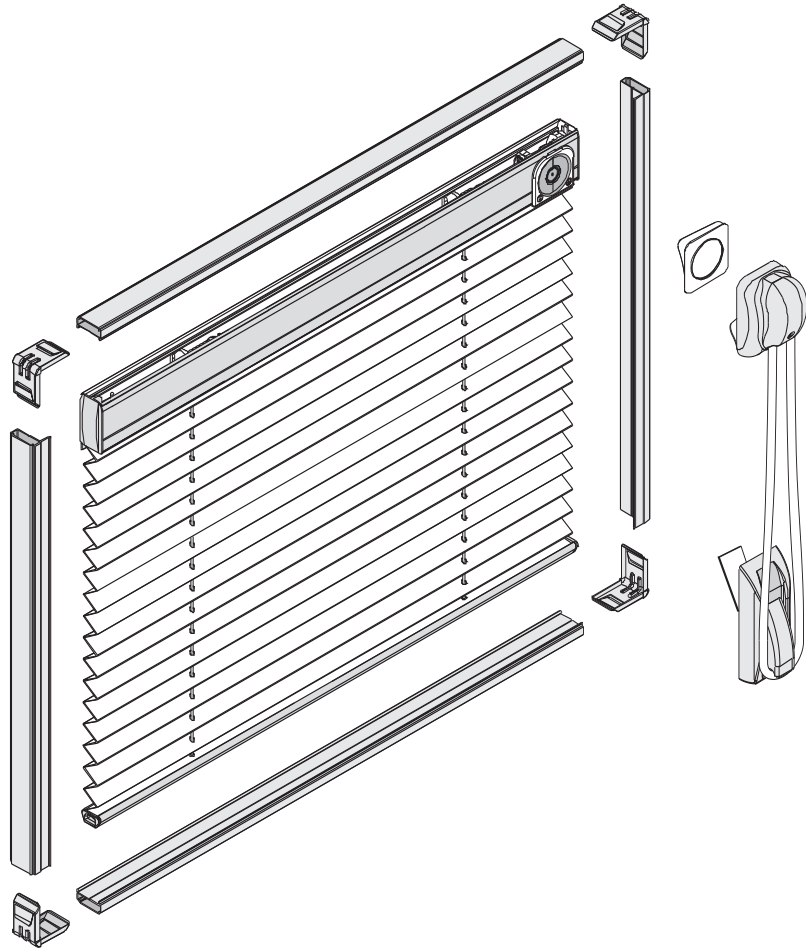

The ScreenLine® pleated blind SL20C for use in double-glazed units, is manufactured in accordance with high technical specification and production standards.

The pleated blind operation is achieved using a rotational magnetic transmission through the glass thereby guaranteeing the unit's hermetic seal.

The external magnet, fixed to the internal glass by double-sided high performance adhesive allows perfect alignment with the internal magnet. The raising and lowering operation is achieved using a continuous cord loop that drives the external magnet. The cord is held lightly under tension by a cord tensioner on the glass directly below the external magnet.

Height	300 ~ 2.500 mm
Width	300 ~ 1.500 mm
Maximum area	see feasibility tables
Blind pack height	2% blind height + 45 mm

## 1. technical features

### Magnetic drive components

Fibreglass re-inforced nylon 66 casing. Transmission gears and parts manufactured from carbon-nitride steel. Ball bearing support for both magnets and gears.

Neodymium-Iron-Boron magnets with the following technical features:

Energy produced	Bh max-Mg.Oe	33-35
Residual induction	Br-Gauss	11.000 / 12.000
Coercive force	Hc-Oestered	10.000
Maximum working temperature	°C	120
Curie temperature	°C	310
Reversible temperature factor	°C	-0.12%

### Head rail

Extruded aluminium, A6063S-T5 alloy. Dimensions: width 18 mm, height 41 mm including pelmet. Powder coated to colours: aluminium grey, white and beige.

Includes interlocking design mechanism for easy and quick assembling of head rail to the upper U-shaped spacer bar.

### Verosol® fabric

Woven polyester fabric, 14 mm pleat, with an aluminium microfilm applied through an exclusive vacuum technique (three-chamber system). The microfilm adhesion complies with the EN-ISO 7523 regulations and the fabric is Class 1 (one) Flame-Retardant. Colours available: 6.

### Vanity fabric

Woven polyester fabric, 14 mm pleat, non flame retardant, not metallized.

Colours available: 2.

### Performance characteristic of the Verosol® fabric

Pleated Verosol Fabric	Solar reflection %	Light reflection %	Solar absorption %	Solar transmission %	Light transmission %
812	71	66	20	9	9
816	52	50	28	20	22
875	74	74	21	5	5

### Performance characteristic of the Vanity fabric

Pleated Vanity Fabric	Light reflection %	Light absorption %	Light transmission %
White C000	46	4	51
Cream C010	40	13	46

### Bottom rail

Extruded aluminium A6063S-T5 alloy. Dimensions: width 15 mm, height 8 mm.

Powder coated to colours: aluminium grey, white and beige.

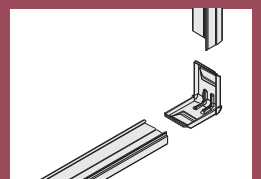
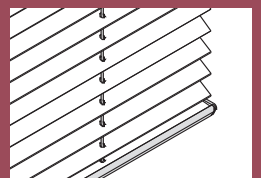
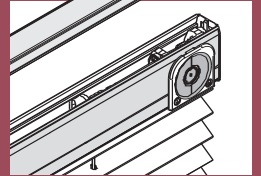

# SL20C plissé

## SL22C plissé

PLEATED BLIND

### Cords

Thermo-fixed 100% polyester with internal core and excellent dimensional stability.

1.0 mm diameter internal cord with centre core - white.

4.0 mm diameter external cord - white, black or light grey.

### Spacer bar

Extruded aluminium. Available in two versions for each system:

SL20: "U" spacer bar dimension 20 x 6.5 mm with 2 mm projection; "L" spacer bar 20 x 6.5 mm with 8 mm projection.

SL22: "U" spacer bar dimension 22 x 6.5 mm with 2 mm projection; "C" profile side guide 22 x 6.5 mm with 8 mm projections.

# SL20C plissé

## 2. technical drawings

### comprehensive drawing with component codes

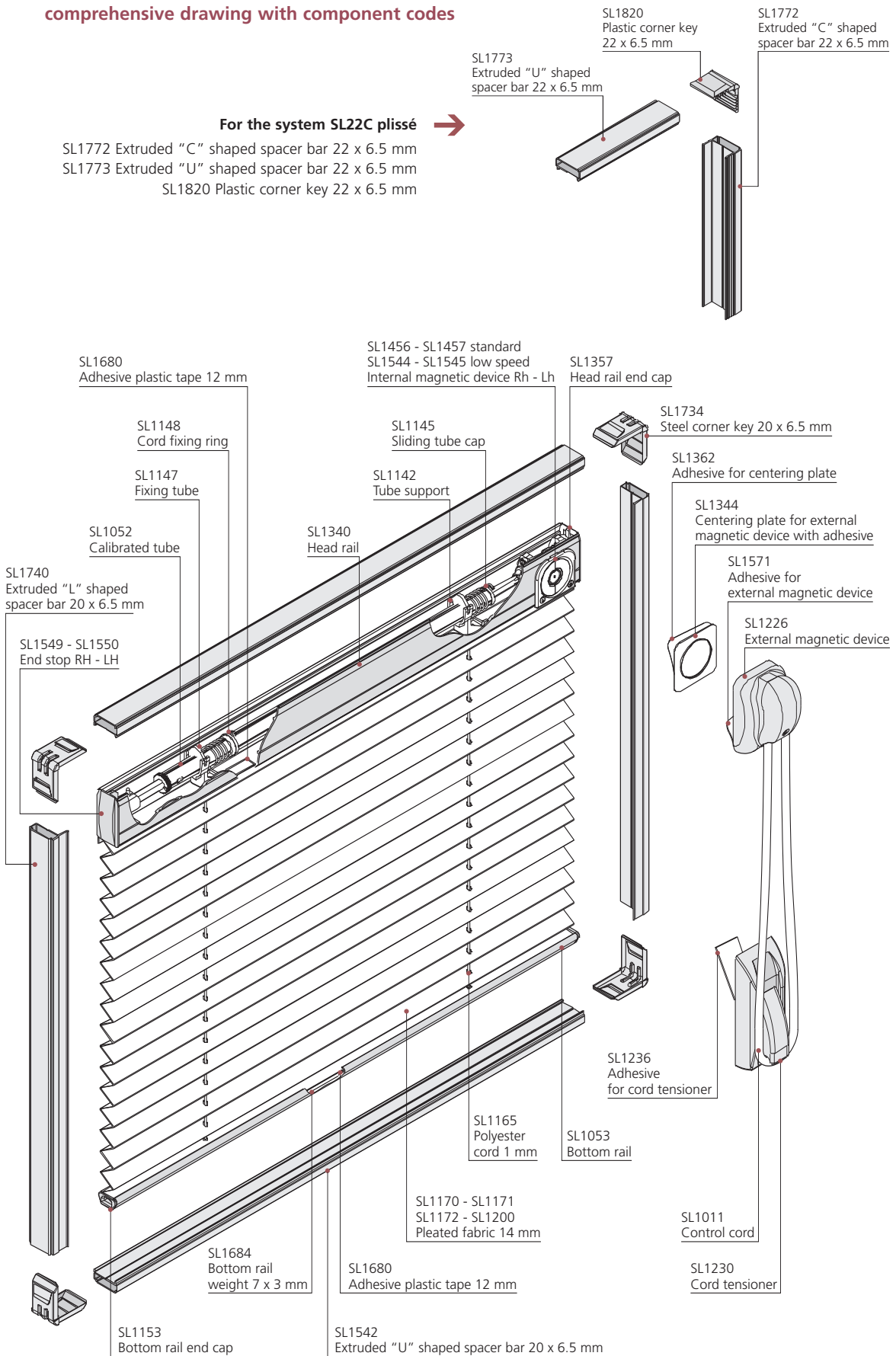

SL22C plissé

SL20C plissé drawing with component codes

pleated blind

SL20C SL22C

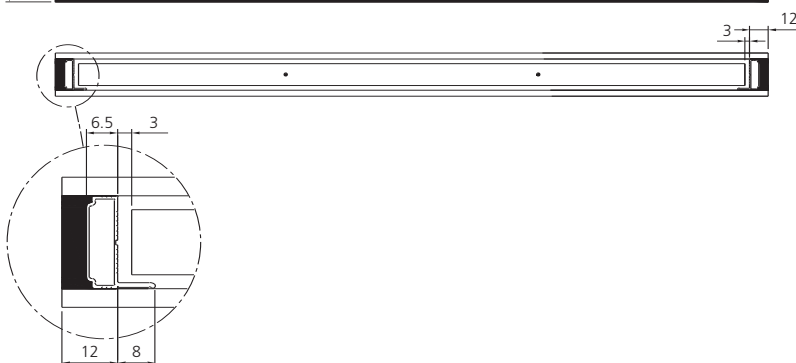
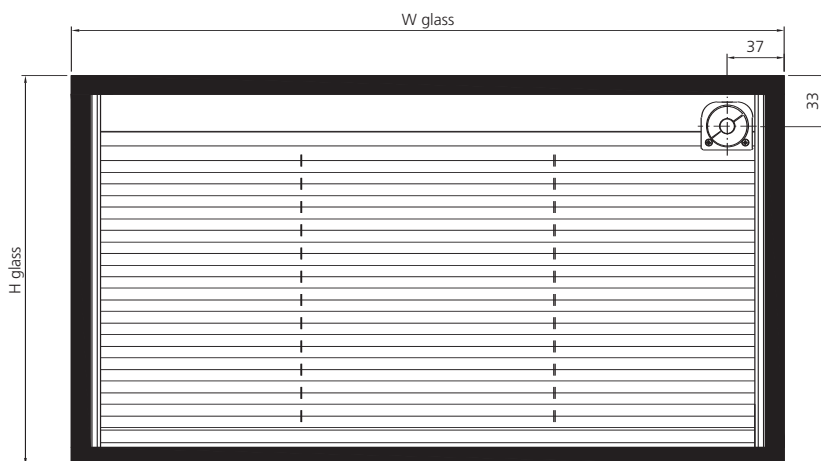

EXTRUDED "L"  
SPACER BAR 20 x 6.5 mm

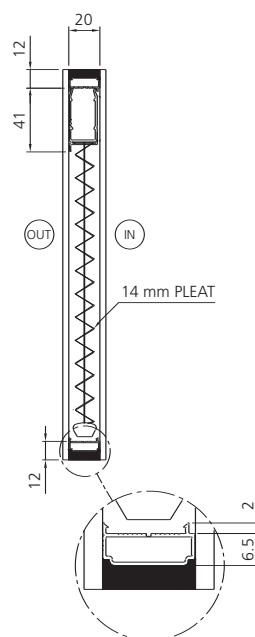

EXTRUDED "U"  
SPACER BAR 20 x 6.5 mm

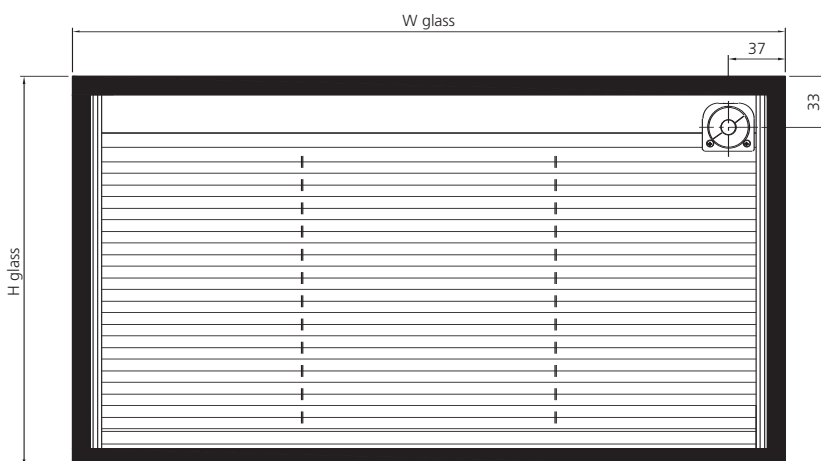

EXTRUDED "C" PROFILE  
SIDE GUIDE 22 x 6.5 mm

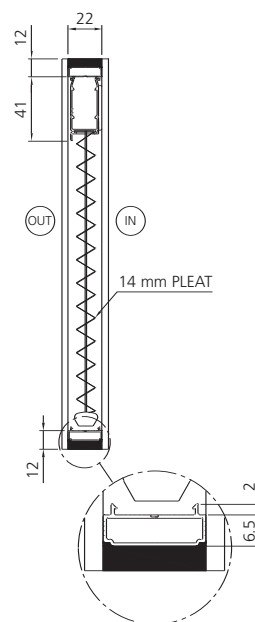

EXTRUDED "U" PROFILE 22 x 6.5 mm

## raising and lowering function

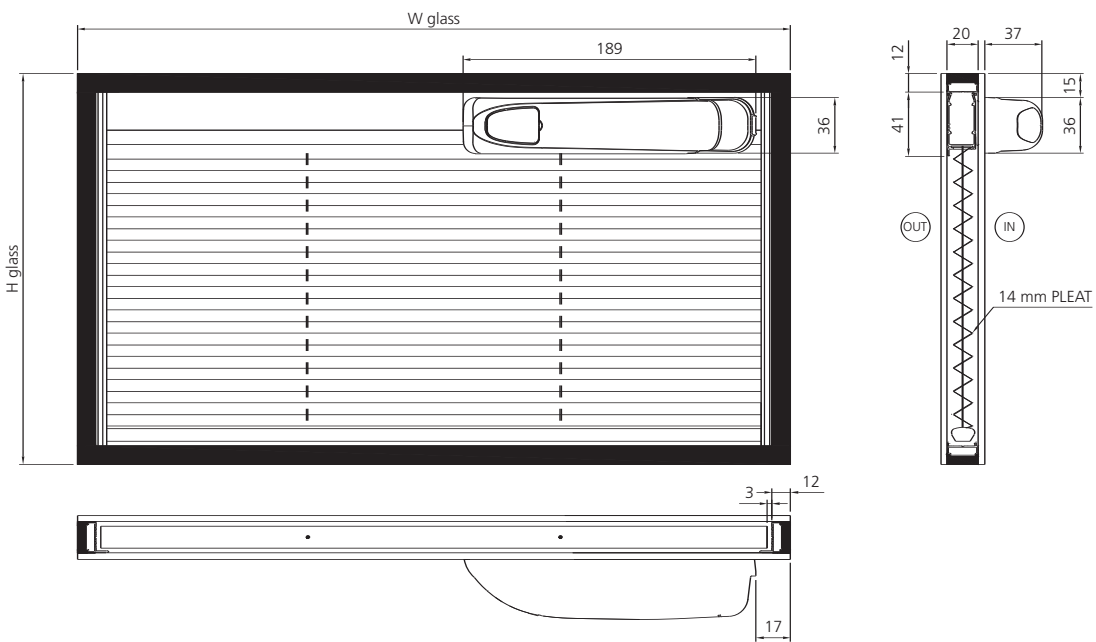
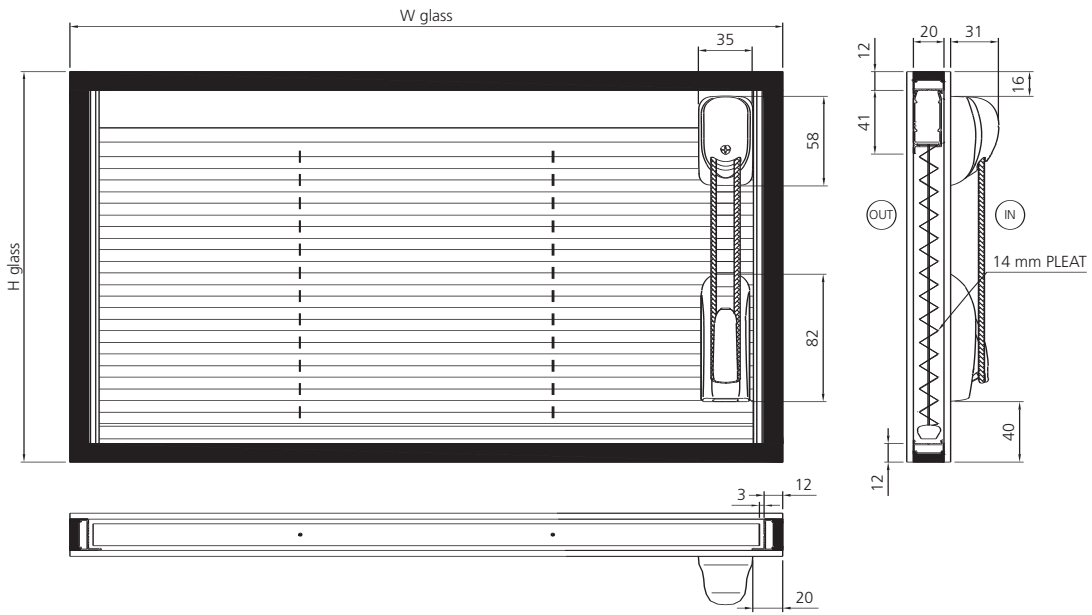

# SL20C plissé

4

glass thickness **4 mm** Monolithic

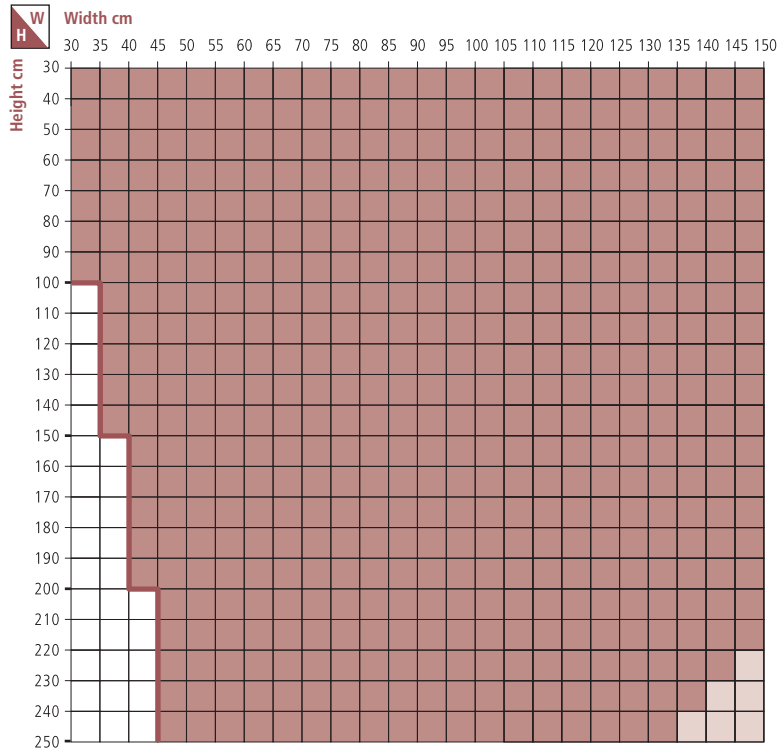

5

glass thickness **5 mm** Monolithic

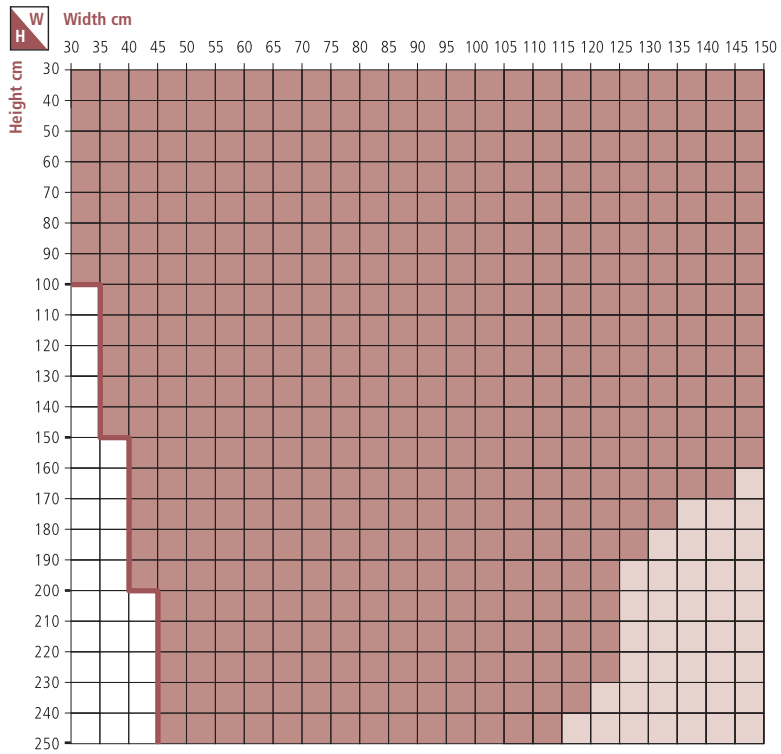

- Raisable with standard speed System
- Raisable with reduced speed System
- Not feasible



### 3. feasibility

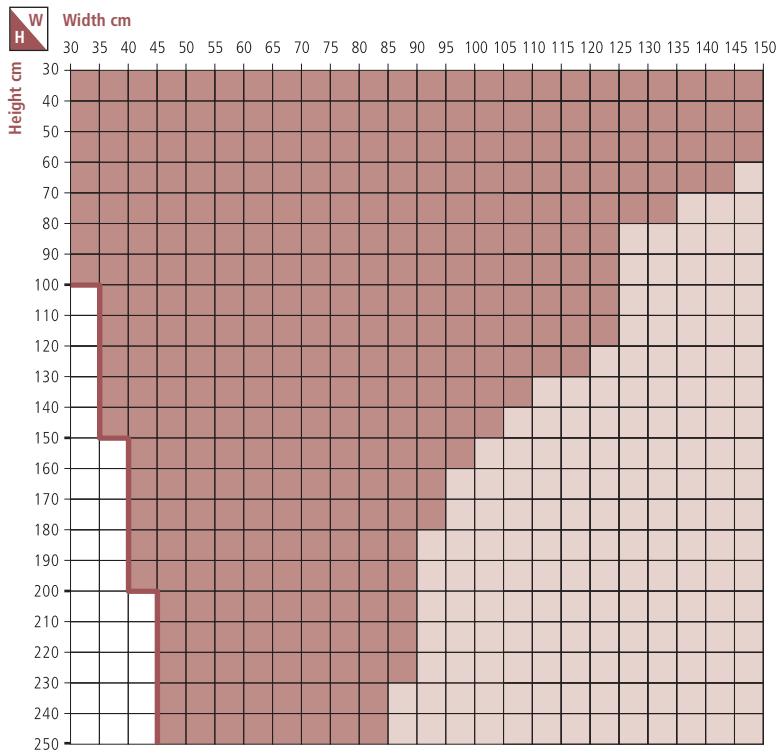
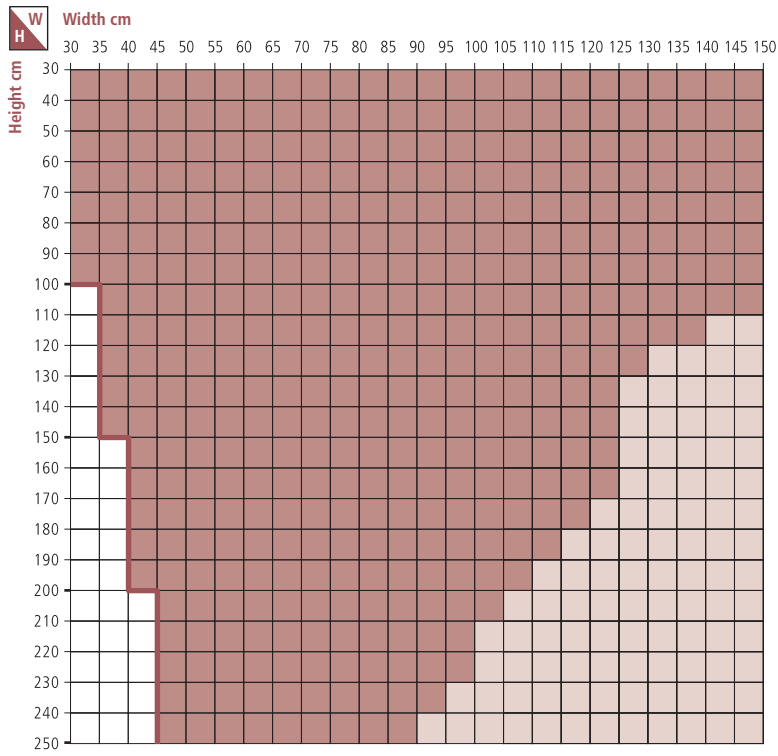

Raisable with standard speed System
  Raisable with reduced speed System
  Not feasible





## 4. assembly instructions

### ScreenLine® kit components

On receipt of the goods, check the integrity of the package and confirm that the components are as detailed on the Purchase Order. The kit includes: **A**

- pleated blind comprising a magnetic control system integrated inside the head rail, which has been factory assembled with the top U-profile spacer bar
- 1 No. bottom U-profile spacer bar (width)
- 2 No. L-profile side spacer bars (height) for the 20 mm cavity system. Alternatively 2 No. C-profile side guides (height) for the 22 mm cavity system
- 4 No. steel corner keys
- external magnetic control kit including aluminium centering base plate plus cord with cord tensioner, all with factory applied adhesive tape.

**Important:** for the SL20C pleated with side L-profile, the projection is designed to be positioned to face 3 (see drawing); for the SL22C pleated with C-profile side guides both surface 2 and 3 are protected.

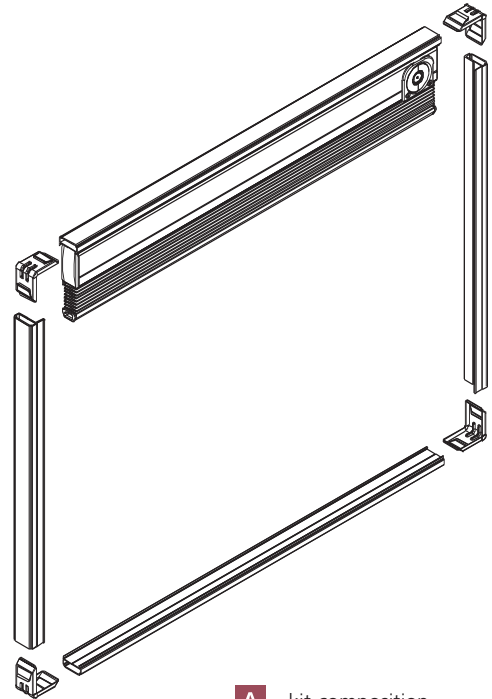

**A** kit composition

### Assembly of the integral blind unit

#### Spacer bars preparation

Fill the appropriate side spacer bars with requisite amount of molecular sieve and assemble them with the bottom spacer bar (ensure that the fin of the L-shaped side spacer bar interlocks correctly with the offset profile of the bottom U-profile spacer bar. **B**

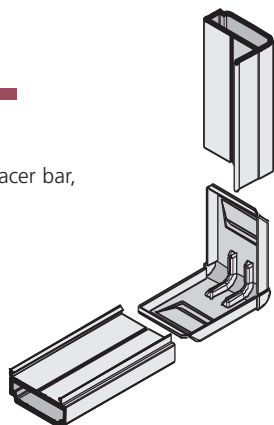

**B1** assembly procedure of the spacer bar, SL20C pleated system

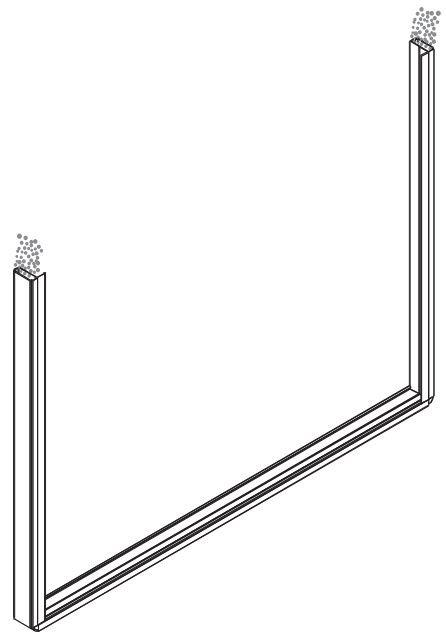

**B** spacer bars - glass assembly

## assembly instructions

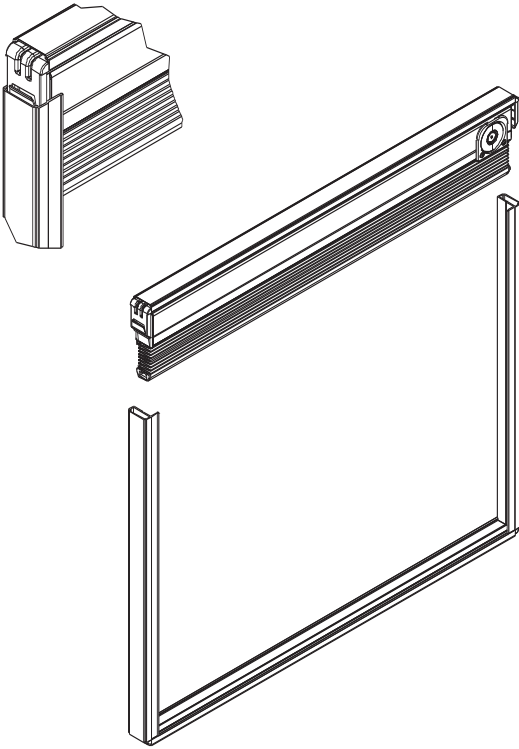

**C** blind insertion on the spacer bars

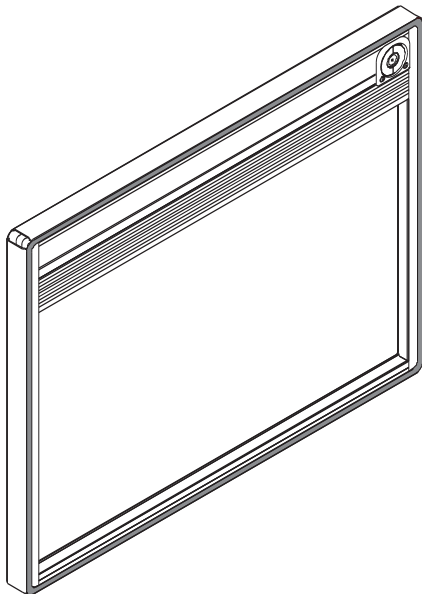

**D** first sealing applying

Assemble with the head-rail / top spacer bar to form the complete spacer frame, ensuring that the magnet is on the same side as the L-profile (i.e. internal face surface 3) avoiding entrapment of the fabric with the projections. **C**

Extrude the butyl primary seal on the formed frame in a continuous line, in accordance with EN 1279-2.

Ensure that the integral blind is not contaminated by butyl etc during this process and that the blind is completely raised. **D**

### Line assembly

Pass the first glass through the washer.

Position the spacer frame and blind uniformly on the glass ensuring it is perfectly parallel and square (avoid inwards deflection of the spacer bar) and press to obtain a high degree of adhesion.

Assemble of the second glass and then proceed with the normal on-line automatic press procedure. **E**

### Gas filling

Following the approved procedure, replace the internal air with argon.

### Testing

Prior to applying the final seal, test that the blind function's correctly using the cord operated external magnetic device - ensuring that the double-glazed unit is positioned vertically with the blind head rail at the top. Check that the movement of the blind occurs freely and that the bottom rail lies parallel on the bottom spacer bar.

### Second sealing

Raise the blind completely apply the final secondary seal in accordance with EN 1279-2. **F**

**Note**

The blind must be completely raised when moving the finished unit either vertically or horizontally otherwise it is possible to damage the blind if it is only partially raised. Capsizing of the blind is possible only if the blind is completely raised.

The centering base plate should be factory applied so that on-site fitting of the external magnet ensures correct alignment of the internal and external magnets.

The glass surface should be cleaned prior to adhesion. (See instruction in the ScreenLine® Technical Catalogue).

The external magnet and cord tensioner should be applied to the glass surface after glazing. Again ensuring that the glass surface is cleaned correctly to obtain good adhesion.

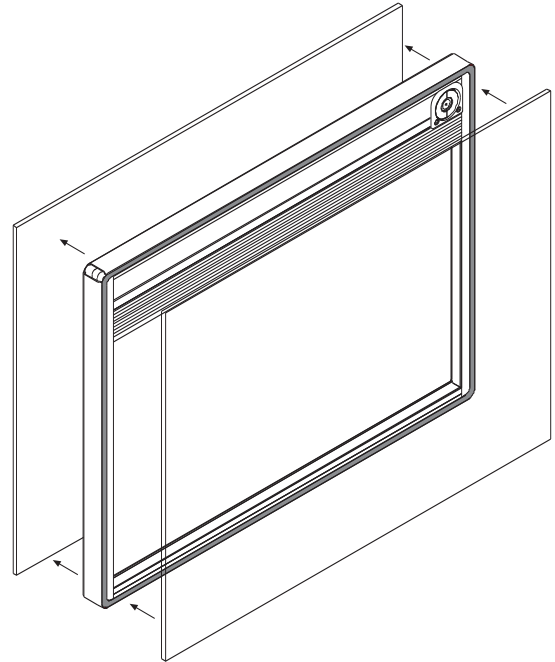

**E** glass assembly

**Transport and Storage**

For transport and storage procedure please check the recommendations contained in the relevant part of the ScreenLine® Technical Catalogue.

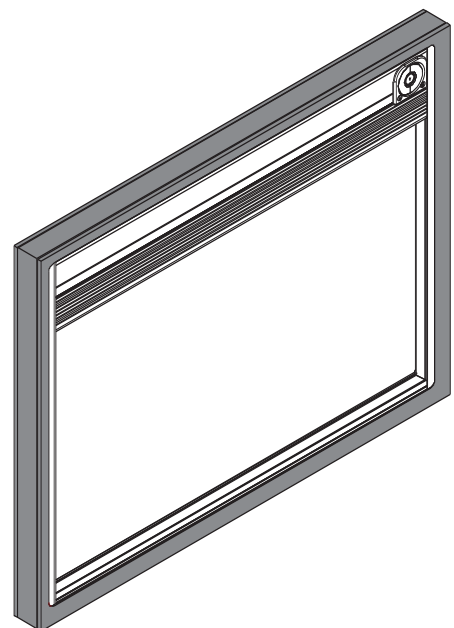

**F** double-glazed unit  
second sealing